



BDC Series

COMPACT MEDIA DUST COLLECTORS



BDC Series



A Compact, Maintenance-Friendly and Cost Effective Dust Collector

The BDC dust collector is a compact, self-cleaning, continuous-duty system that economically meets the needs of most every industrial dust collection application. This advanced system utilizes a pulse-jet cleaning system that effectively “pulses-off” the captured dust and cleans the filter while the system stays on-line. With minimal pressure drop, the BDC’s many filter media options maintain 99.9%+ filtration efficiency.

The BDC Series provides superior design and performance with advanced, maintenance-friendly features. Its heavy-duty, rugged construction and factory-assembled sections ensure quick installation and years of dependable performance.

Solutions for Many Different Applications

With its versatile construction and multiple media filter options, the BDC can meet virtually any manufacturing dust collection application including:

- Food Processing
- Woodworking
- Molding, Grinding & Polishing
- Rock, Stone & Glass Operations
- Secondary Smelting
- Pharmaceutical
- Metalworking
- And More

Maintenance-Friendly

Designed with end users in mind, the BDC collector is engineered for fast, tool-free, safe maintenance and filter change-out. Instead of systems that require workers to crawl inside the unit (a practice that is time consuming, dirty and dangerous), the BDC's filters can be removed quickly by unlocking the cam bar and simply sliding the filter trays out. This ensures worker safety and greatly reduces necessary service time. Also, the BDC provides online continuous cleaning, so it requires little maintenance.



Energy Efficient

The BDC's advanced design ensures low pressure drop resulting in reduced blower horsepower requirements and improved energy savings. Its low compressed air requirements and optional safety after-filter allows recirculation, eliminating the need for costly make-up air.

Compact Design

Ideal for low headroom applications, the BDC's compact design greatly reduces the amount of valuable floor space while providing up to 1,640 sq. ft. of media at 99.9%+ filtration efficiency. And because the system is so compact and can be specified with one of multiple discharge designs such as a hopper, dust drawer or bin vent, placement within your factory or outside your facility is easily accomplished!

Configured to Meet Your Specific Needs

The BDC is designed with multiple filter options so that it can effectively capture airborne pollutants for virtually any dust collection application. To ensure proper media filtration for your application, the BDC can be ordered with Cartridges, Felted Bags or Spun-Bond Pleated Bags. A UAS Representative can help you select the right filter option that meets your requirement.





Features & Benefits

Springless Pulse Valves

Provides durable performance with long-lasting durability.

Custom Air Inlet/Outlet Locations

Location of inlet and outlet can be specified to meet installation requirements.

Powder-Coated Finish

All components have electrostatically applied paint that helps prevent fading and chalking.

Heavy-Duty Supports

Designed and manufactured to meet seismic zone 4 and 100 mph wind load structural rating.

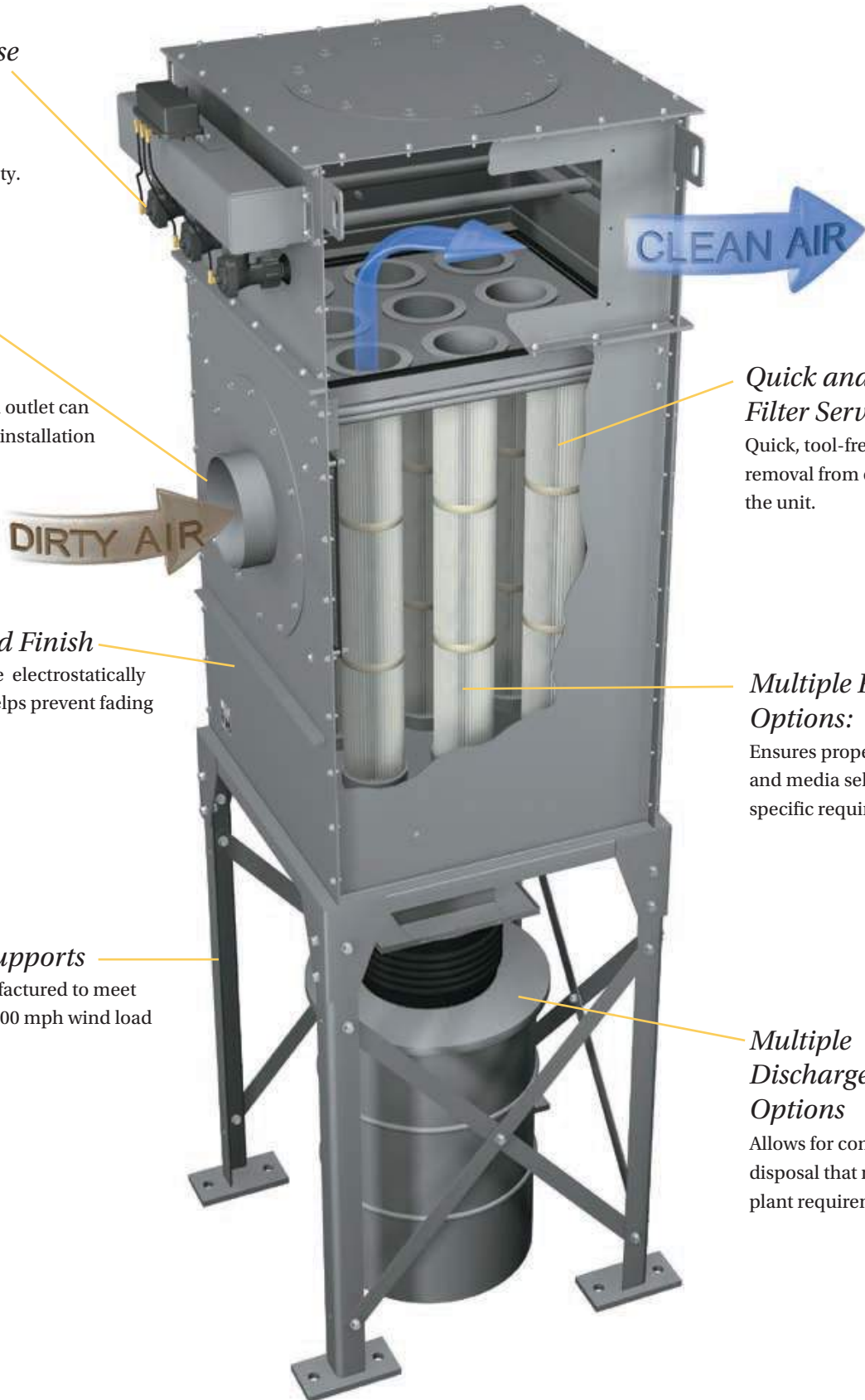

Quick and Easy Filter Service

Quick, tool-free filter removal from outside the unit.

Multiple Filter Options:

Ensures proper filter type and media selection for your specific requirements

Multiple Discharge Options

Allows for convenient dust disposal that matches your plant requirements.

Filters

The advanced BDC collector offers the largest selection of high filtration media filters for applications with even the most demanding requirements. The BDC system has been designed so that it can easily be configured to meet your specific needs utilizing four basic filter options listed below:

10" CARTRIDGE

Durable filter designed to ensure minimal installation time with high filtration. Available as standard with a non-woven, proprietary material blend with molded end caps that helps resist abrasive wear. Other cartridge materials are available for unique applications such as: fire retardant, wide pleat, washable, high-strength (Spun-Bond) quick release media, PTFE, high temperature and graphite impregnated.



6" PLEATED BAGS

The superior performance bag filter for applications up to 265° F. Features 100% spun-bond media and durable molded urethane top and bottom end caps to ensure long life and energy savings. Multiple material options include: oil/water repellent finish, PTFE membrane bonded to spun-bond and conductive impregnation.



6" FELTED BAGS

An economical, 16-oz. felted bag filter which offers durability and high-filtration efficiency. Designed as standard for 275° F temperature applications, these filters can also be ordered for high temperature needs (up to 500° F) and with a wide variety of finishes including: napped, singed, glazed, silicone treated, fire retardant, Teflon, acid resistant, chemical resistant and silicone/graphite impregnated.



2" FELTED BAGS

More effective than 6" felted bags, these 16-oz. polyester media filters provide high-filtration efficiency designed for 275° F maximum temperature applications. Available with same options and finishes as 6" felted bags.

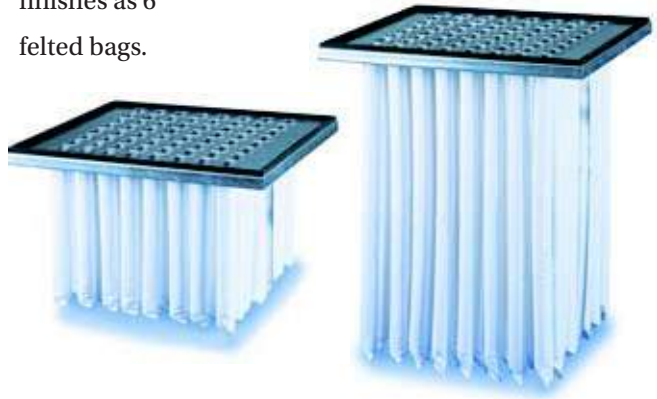

Unit	Filter Media (Sq. Ft.)				Filter Quantity			
	10" Cartridge	6" Pleated Bag	6" Felted Bag	2" Felted Bag	10" Cartridge	6" Pleated Bag	6" Felted Bag	2" Felted Bag
BDC-11	410	166	23	55	4	9	9	64
BDC-12	820	331	46	109	8	18	18	128
BDC-13	820	331	46	109	8	18	18	128
BDC-14	N/A	662	92	219	N/A	36	36	256
BDC-21	820	331	46	109	4	9	9	64
BDC-22	1640	662	92	219	8	18	18	128
BDC-23	1640	662	92	219	8	18	18	128
BDC-24	N/A	1325	185	439	N/A	36	36	256

Options and Accessories

UAS provides a comprehensive selection of options and accessories to enhance the performance of your BDC dust collection system.

Some of these include:

- **Return Air Safety Filters** –

Used when air is recirculated into the plant or when collecting hazardous dusts, ensuring that clean air is continuously discharged from the unit.

- **Pressure Relief Panel** –

Minimizes damage and provides a degree of personal protection in the unlikely event of an explosion that may result when collecting explosive dusts.

- **Silencer Package** – Duct-type silencer reduces unit noise levels. (80 dBA as specified)



Pressure Relief Panel

- **Fully Welded Cabinets** – Provide a complete air-tight seal to meet unique specifications.
- **Differential Pressure and Pulse Control Panel** – Continually monitors operation and displays status while providing multiple pre-determined user cleaning modes.



Differential Pressure and Pulse Control Panel



Blower and Silencer Package

Additional Options / Accessories

- Stainless Steel Construction (304/316, 2B Finish)
 - Fans / Integral Blowers
 - Leg Extensions
 - Drum Lid Kits
 - Drum Lid Latch Kits
 - Photohelic© Gage Controls
 - Hopper Access Doors
 - Sprinkler Couplings
 - Thermal Protection Kits
 - Ground-Mount Blowers
 - Control Panels
 - Other options and accessories available
- Contact UAS for assistance.

Dimensions and Specifications

Unit Dimensions

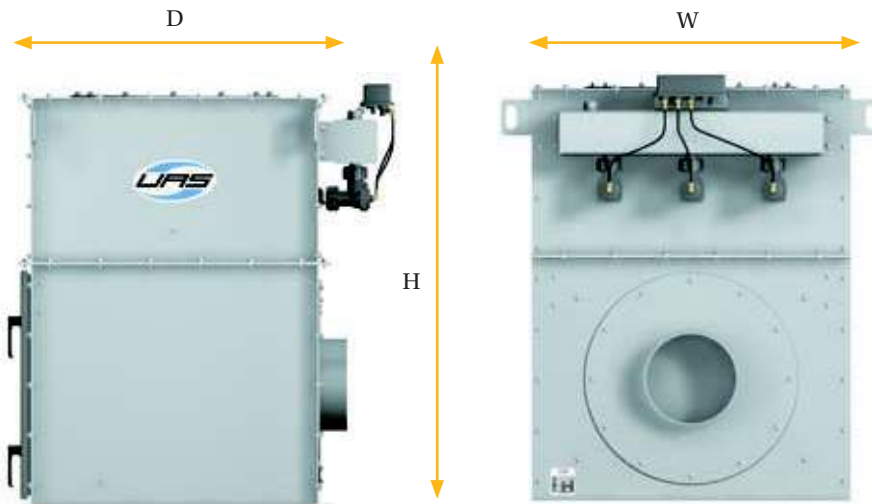

Model	Height						Width	Depth	Unit Weight* (lbs.)	Compressed Air Consumption	
	Unit (Bin Vent)	45 Hopper		60 Hopper		Dust Drawer				SCF 1 Pulse	SCFM 6 Pulses/Min
		55-gal	30gal	55-gal	30-gal						
BDC-11	47"	104.5"	88.5"	113"	97"	61"	35"	35"	523	0.8	4.8
BDC-12	47"	104.5"	88.5"	113"	97"	N/A	67"	35"	891	1	5.8
BDC-13	47"	104.5"	88.5"	113"	97"	N/A	35"	67"	891	1	5.8
BDC-14	47"	120"	104"	140"	124"	N/A	67"	67"	1347	1.2	7.2
BDC-21	66.5"	124"	108"	132"	116"	80"	35"	35"	657	0.8	4.8
BDC-22	66.5"	124"	108"	132"	116"	N/A	67"	35"	1089	1	5.8
BDC-23	66.5"	124"	108"	132"	116"	N/A	35"	67"	1089	1	5.8
BDC-24	66.5"	139.5"	123.5"	159"	143"	N/A	67"	67"	1593	1.2	7.2

*Cabinet weights do not include discharge options

Discharge Option Dimensions

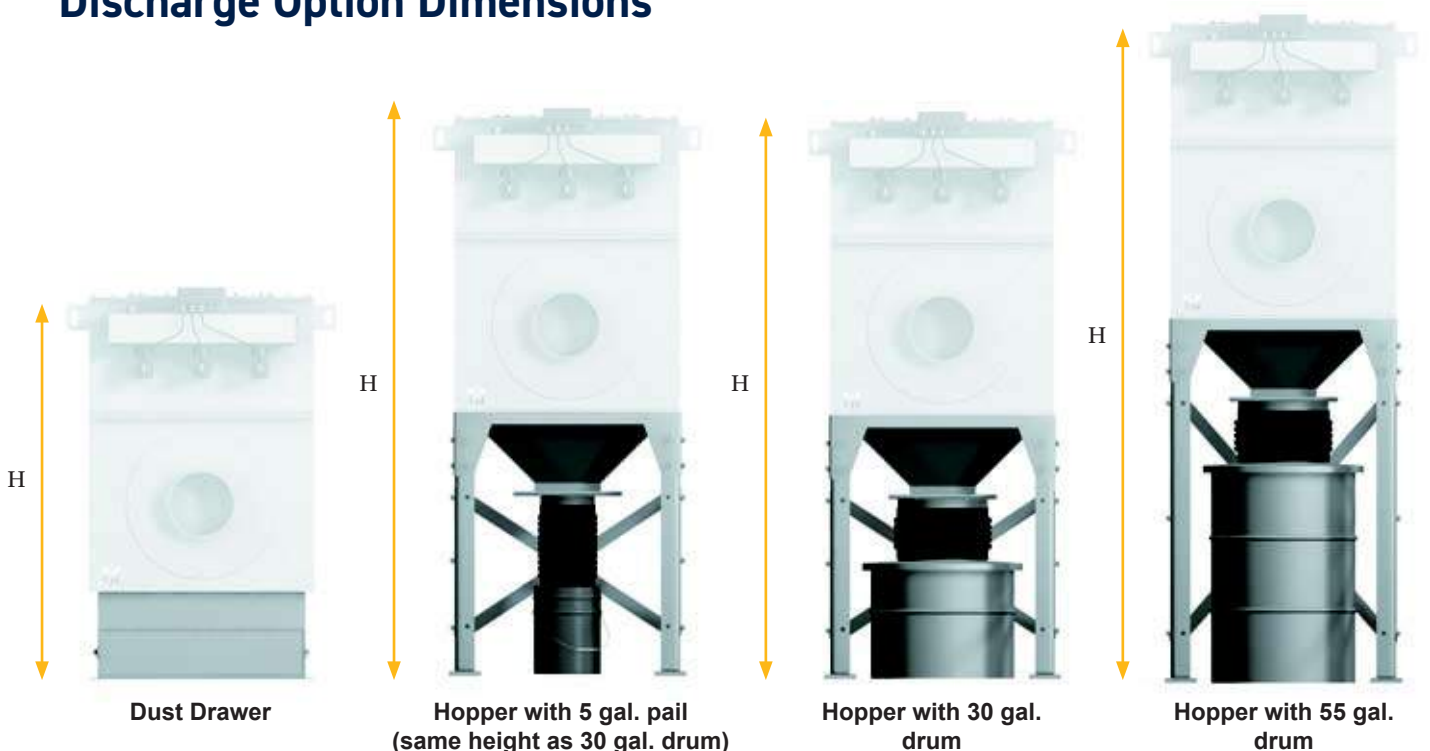



Why Choose United Air Specialists?

A world-renowned reputation. For more than 40 years, we've been the industry leader in air quality technology — a proven track record that speaks for itself.

Commitment to quality products. Measuring our quality against documented expectations, we practice continuous improvement methods to anticipate challenges and implement successful solutions.

Unparalleled customer support. As a customer-driven solutions provider, we earn credibility and establish successful relationships by exceeding expectations for professional service and attitude.

Innovative technical leadership. Always, we keep technology at the forefront — ensuring continuous product advancements through ongoing investments in design and manufacturing.

Poche Engineering Pty Ltd
15 Broadhurst Rd
Ingleburn NSW, 2565
Ph: +61 2 9618 6777

